

版本 REV.	日期 DATE	ECN NO.	变更内容 DESCRIPTION	制图 DRAWN

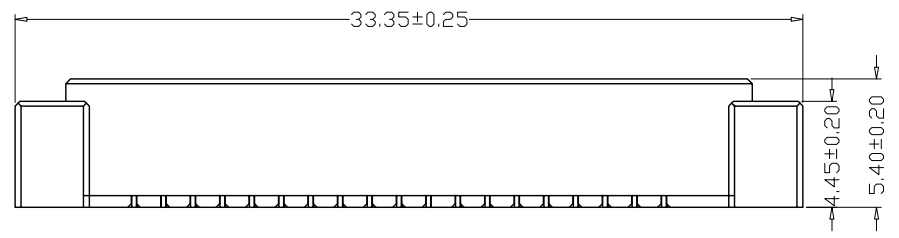
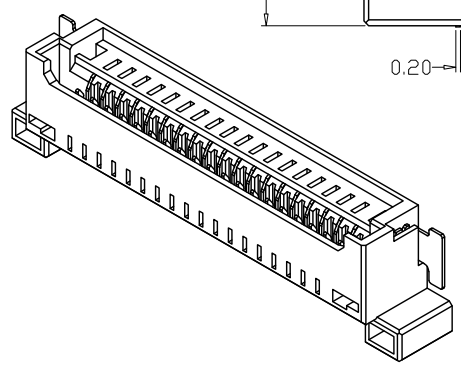
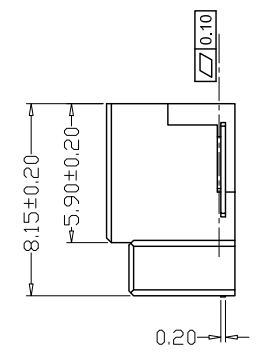
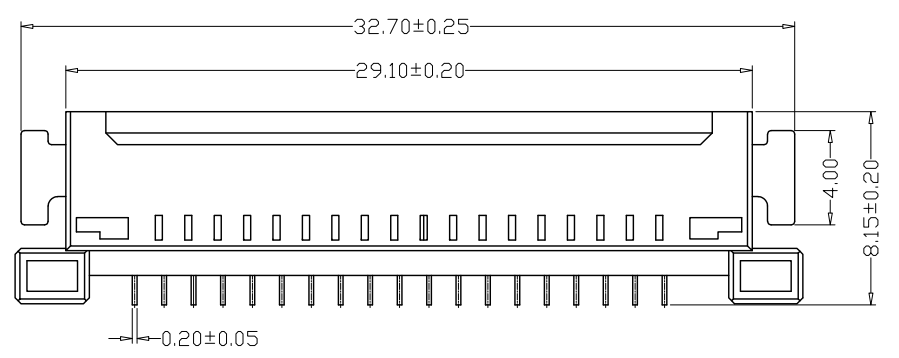
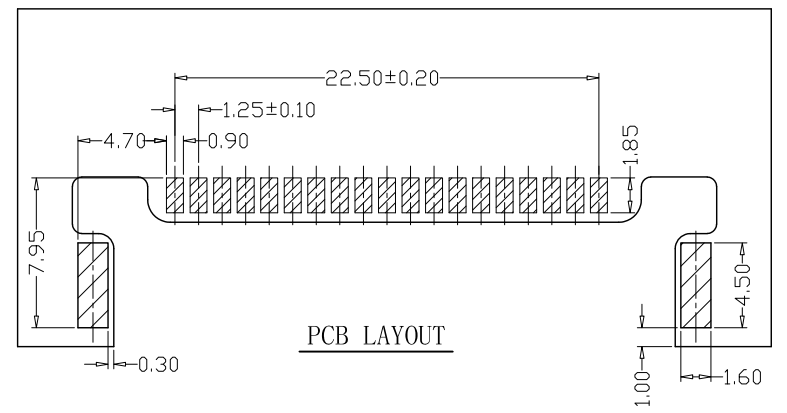
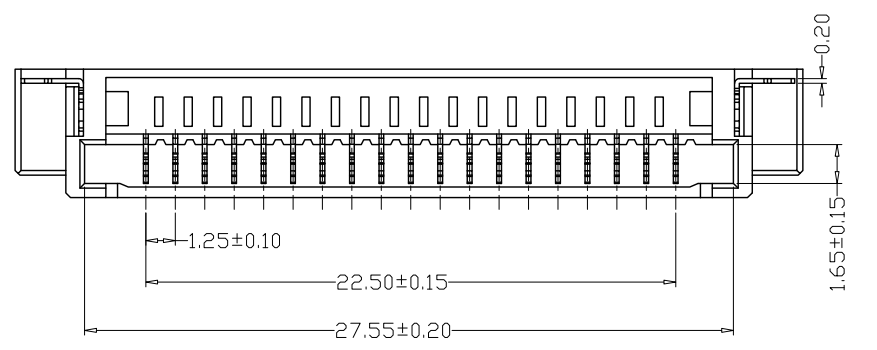

- SPECIFICATIONS**
- Current Rating: 1A AC, DC
  - Voltage Rating: 125V AC, DC
  - Temperature Range: -25°C~+85°C
  - Contact Resistance: 20mΩ Max
  - Insulation Resistance: 100MΩ Min
  - Withstanding Voltage: 500V AC/minute
  - Material  
Wafer: PA6T UL94V-0  
PIN: Phosphoric bronze Tin-plated  
Solder tab: Phosphoric bronze Tin-plated

GENERAL TOLERANCE		制图	张迎春		料号	B12510-19AWB	版本	A
X.X±0.25	X.*±2'	DRAWING	2022、08、29		PART NO.		REV.	
X.XXX±0.10		审核	钱岳生		品名	12528-19P卧贴	页次	1/1
X.XX±0.20		CHECK	2022、08、29		TITLE	WAFER SMT TYPE	SHEET	
		核准	张名		客户料号			
		APPROVAL	2022、08、30		CUTM. NO.			
		单位	MM	比例	乐清市宏一电子有限公司 YueQing HongYi Electronics Co., Ltd			
		UNITS		SCALE				